

FL1000

FLOOR LEVEL PALLETIZER

The FL1000 floor level palletizer provides an optimal price and speed combination for low speed applications. Small enough to be moved through an 8' x 8' doorway, the FL1000's compact footprint utilizes less than 60 square feet of floor space. Requiring no modification, the FL1000 can handle a wide variety of package types, including cases, trays, totes, film only and display packs from a variety of industries. The FL1000 palletizes 10 cases per minute or more, depending on case size and pallet pattern.



FEATURES

- Comprehensive Guard Package
- Category 3 Safety Electrical System
- Interlocked Access Doors to Load Build Area
- Full Height Light Curtains at Discharge
- Automatic Hoist Protection Pins
- Product Manager for Pattern Creation and Tuning
- Heavy Duty Sensor Mounts
- 4-Sided Pallet Stack Retention
- Stack Light / Beacon
- Smart Squeeze Technology for Misformed Layer Detection
- Low Pallet Detection
- Low Sheet Detection
- Heavy Duty Construction
- 80 Pitch Hoist Chain
- Infeed Tunnel Guard
- UL Approved or CSA Certified Control Panel
- Ethernet Enabled PLC with Distributed I/O

COMMON PALLETIZER LAYOUTS

- ① **Infeed**
- ② **Palletizer**
- ③ **Pallet Dispenser (optional)**
- ④ **Discharge Conveyor (optional)**

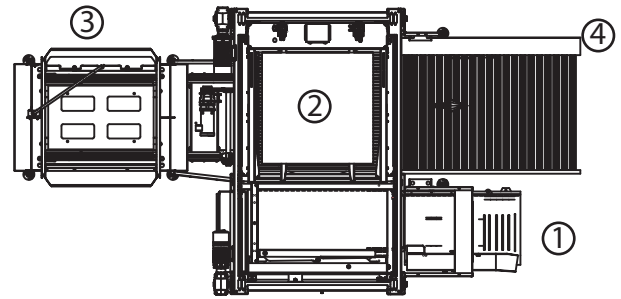
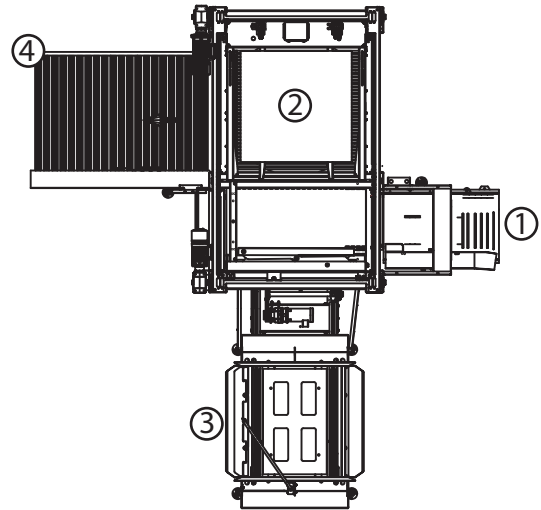
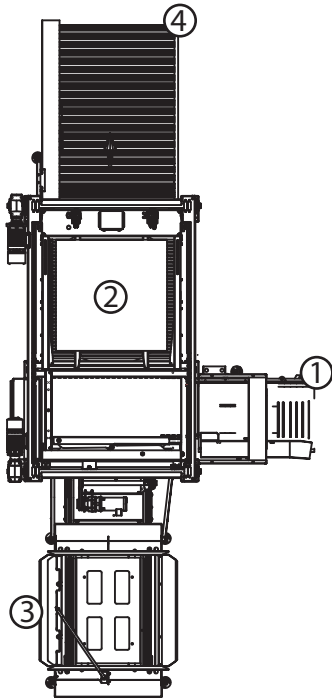

OPTIONS

- Wireless controls interface
- Labels-out stacking
- Speed enhancement upgrades
- FDA accepted stainless steel paint
- Upstream and downstream conveyor and interfacing
- Integrated stretch wrapper
- Discharge conveyor
- Slip / Tie / Cap sheet dispenser
- Unitizing
- Turnkey system integration
- Soft product handling